

## LEFOO 力夫

LEFOO (GROUP) CO.,LTD/ LEFOO INDUSTRIAL CO.,LTD

Lefoo Industrial Co.,Ltd / Zhejiang Lefoo Sensing Technology Co., Ltd  
No.118, Changda Road, Linping Street, Yuhang District, Hangzhou, Zhejiang, 311100 China  
Mobile/WhatsApp/Wechat: +86-18268876736  
E-mail: export14@lefoo.com <https://en.lefoo.com.cn>



QUICK-INSTALLATION  
PERISTALTIC PUMP  
LFP101-LFP201





## ABOUT LEFOO

Hangzhou LEFOO Industrial Co.,Ltd is jointly invested by Zhejiang LEFOO Industrial Co.,Ltd and HK Hosung Industries Limited Company, It covers an area of 50000 square meters with investment of 30 million dollars, and devotes continuous exploration and innovation to RO booster pumps, pressure switches, compressed air purification equipments etc.

Besides a comprehensive range of standard products, LEFOO professional technological team and a well equipped R&D center make it able to offer specific customer solutions, especially designed to meet particularly actual requirements.

Huge investments in R&D not only assure versatile solutions and great flexibility to meet the present market demands but also guarantee cost-effective product features and performances.

The successful and lasting presence in North America, Europe, Asia, Australia, and South America, also strengthened by the prestigious TUV ISO 9001:2008 certification and by many other specific product approvals prove LEFOO to be a qualified international manufacturer able to suit the most various and demanding technological requirements.

LEFOO products and technology are widely used in industry of household appliances, petrochemical, metallurgy, electronics, electric power, textile, food, medicine, biology, papermaking, automobile manufacturing, machinery etc.



QUICK-INSTALLATION PERISTALTIC PUMP



TYPICAL APPLICATIONS

<ul style="list-style-type: none"> <li>Detergent supply : Dish-Washing machine, Washing machine</li> </ul>	<ul style="list-style-type: none"> <li>Analytical Equipment : Analytical &amp; testing instrument sample supply</li> </ul>
<ul style="list-style-type: none"> <li>Printing Equipment : Ink Supply</li> </ul>	<ul style="list-style-type: none"> <li>Food Machinery : Drink dispenser</li> </ul>
<ul style="list-style-type: none"> <li>Kitchen Apparatus</li> </ul>	<ul style="list-style-type: none"> <li>Laundry Apparatus</li> </ul>
<ul style="list-style-type: none"> <li>Car Washing Equipment</li> </ul>	<ul style="list-style-type: none"> <li>Analytical Apparatus</li> </ul>

PRODUCT FEATURES:

- Powerful torque
- Customized flow, LFP101 up to 88ml/min, LFP201 up to 650ml/min
- 2、3、4 rollers for LFP101 ; 2 rollers for LFP201
- LFP101 has 1mm and 1.6mm two types of tube thickness, maximum inner diameter 4mm, LFP201 tube thickness is 1.6mm, inner diameter reaches up to 6.4mm
- Pump head is convenient for disassembly and assembly ,which makes it convenient for tube replacement
- DC motor and stepper motor are both available (revolutions setting controller is standard configuration, flow can be adjustable). The stepper motor satisfies the requirement of long term usage with low noise
- Skyblue for LFP104 pump housing, 3 colors (skyblue, colorless transparent and yellow) available for LFP204 pump housing. Random delivery will be made if no request for the colors.

MODEL SELECTION

Intermittent operation, strict cost control and no requirements of the flow accuracy, please choose DC motor; if you want to control the flow accurately with a long life motor, please choose stepper motor.

To be noticed: keep low speed on the condition of continuous operation (within 150rpm).

● LFP101



LFP104 PRODUCT PARAMETER

Items	LFP101 ( DC motor )	LFP101/BT (Stepper motor)
Rotate Speed Range	5、10、30、50、60、100、150	0.15~200
Tube Size	Tube thickness:1mm and 1.6mm,Inner diameter:1.6~4mm 2×1、3×1、4×1、14#(1.6×1.6)、16#(3.2×1.6)	
Flow Range	0.75-88	0-150
Rollers	2 rollers、3 rollers、4 rollers	
Motor Power	3-12	5-30
Motor Model	28 series DC electric motor	42 series Stepper motor
Voltage	12、24	10~30
Weight	0.2	0.36

LFP101 Specification ( ml/min,media: water)

LFP101 peristaltic pumps flow table (2 Rollers)					
Tube/Inner diameter* Thickness	2×1	3×1	4×1	14#	16#
Revolutions					
5	1	1.6	2.2	0.85	1.6
10	2.1	4.8	5.2	1.7	3.2
30	4.8	11	15	5	7.3
50	10	23	30	10.5	15.5
60	11.5	26	37	12	16.5
100	24	53	78	25	35
150	28.5	61	88	29	41

LFP101 peristaltic pumps flow table(3 Rollers)					
Tube/Inner diameter* Thickness	2×1	3×1	4×1	14#	16#
Revolutions					
5	1	1.2	1.2	0.75	1.7
10	1.9	3.2	3	1.2	2.8
30	4	7.7	9	4.2	7.4
50	8	14.5	17	9.4	11
60	9.7	17	20	10.5	12.8
100	20	32	45	20	27
150	24	39	43	22	30

LFP101/BT Specification(ml/min , media:water)

LFP101/BT peristaltic pumps flow rate table(2 Rollers)					
Inner diameter X Thickness	14#	16#	2×1	3×1	4×1
Rotate Speed(rpm)	0-200	0-200	0-200	0-200	0-200
Flow Range(ml/min)	0-35	0-75	0-35	0-85	0-150

LFP101/BT peristaltic pumps flow rate table(3 Rollers)					
Inner diameter X Thickness	14#	16#	2×1	3×1	4×1
Rotate Speed(rpm)	0-200	0-200	0-200	0-200	0-200
Flow Range(ml/min)	0-25	0-50	0-25	0-55	0-70

LFP101 Pump drawings:

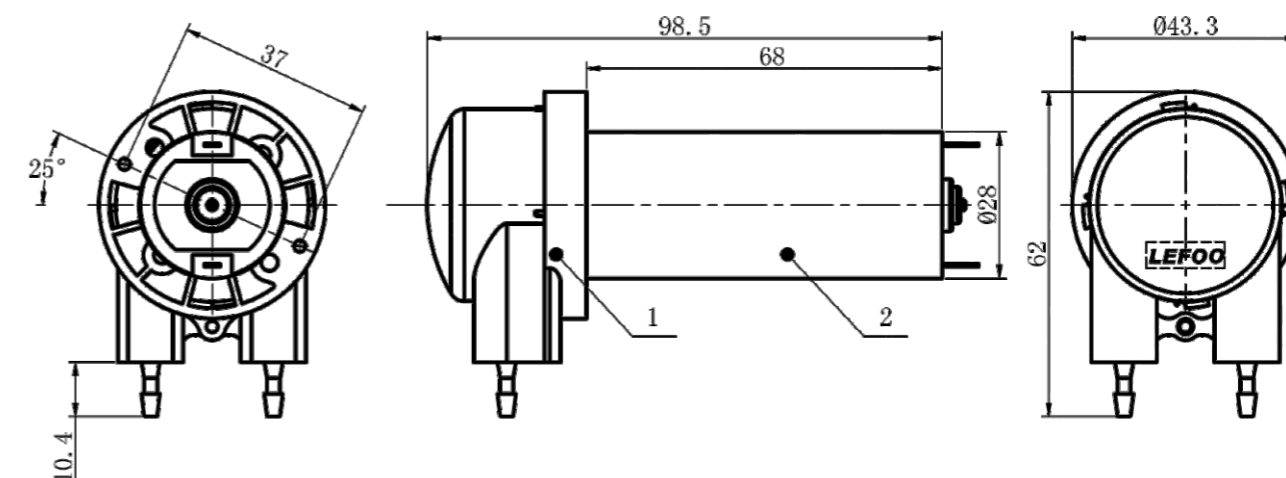

LFP101 Pump drawings:

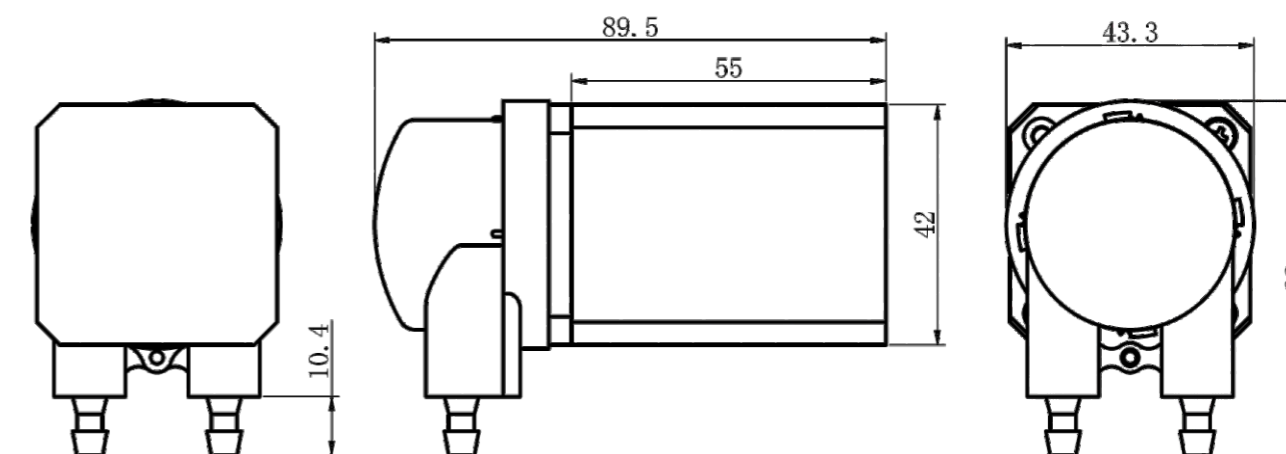

# ● LFP201



## LFP201 PRODUCT PARAMETER

Items	LFP201 ( DC motor )	LFP201/BT (Stepper motor)
Rotate Speed Range	25、50、100、150、200、300	0.15~200
Tube Size	Tube thickness: 1.6mm, Inner diameter: 3.2、4.8、6.4mm 16#、17#、25#	
Flow Range	20-650	0-500
Rollers	2 rollers	
Motor Power	6-16W	25-50W
Motor Model	37 series DC electric motor	57 series Stepper motor
Voltage	12、24	10~30
Weight	0.5	0.7

## LFP204 Specification ( ml/min,media: water)

LFP204 peristaltic pumps flow table			
Tube/Inner diameter* Thickness	16#	25#	17#
Revolutions			
25	20	40	*
50	44	90	*
100	70	153	245
150	134	272	455
200	155	315	500
300	215	445	600

## LFP201/BT Specification ( ml/min,media: water)

LFP201/BT peristaltic pumps flow rate table			
Inner diameter X Thickness	16#	25#	17#
Rotate Speed(rpm)	0-200	0-200	0-200
Flow Range(ml/min)	0-155	0-315	0-500

## LFP201 pump drawings:

