

LEFOO Brushless RO Booster Pump**Features:**

- ◆ Brushless, long lifetime.
- ◆ Equipped with high power brushless DC motor with super low noise, low vibration.
- ◆ Protection function on over current, over voltage, under voltage, over temperature, blocking rotation.
- ◆ Energy-saving and environmental protection, No sparks when working, explosion-proof advantage.
- ◆ Compliant with ROHS & CE certification.
- ◆ The wet parts complies food grade requirements.

Specification:

Model	LFP1300W-B	LFP1400.2W-B	LFP1500W-B	LFP1600W-B
Voltage	24VDC	24VDC	24VDC	24VDC
Connection Size	3/8"NPT	3/8"NPT	3/8"NPT	3/8"NPT
Inlet Pressure	0.2MPa	0.2MPa	0.2MPa	0.2MPa
Working Pressure	0.5MPa	0.5MPa	0.5MPa	0.5MPa
Working Current	≤2.4A	≤3.0A	≤2.5A	≤3.0A
Working Flow	≥2700ml/min	≥2950ml/min	≥3250ml/min	≥3600ml/min
Open Flow	≥3500ml/min	≥4000ml/min	≥5000ml/min	≥6000ml/min
Bypass Pressure	0.85~1.0MPa	0.85~1.0MPa	0.85~1.05MPa	0.85~1.05MPa
Maximum Current	3.2A	4.0A	3.7A	4.5A

Model	LFP2800W-B	LFP21000W-B
Voltage	36VDC	36VDC
Connection Size	3/8" NPT	3/8" NPT
Inlet Pressure	0.2MPa	0.2MPa
Working Pressure	0.7MPa	0.7MPa
Working Current	≤3.5A	≤4.0A
Working Flow	≥4000ml/min	≥5000ml/min
Open Flow	≥6500ml/min	≥6500ml/min
Bypass Pressure	0.9~1.2MPa	0.9~1.2MPa
Maximum Current	4.0A	5.0A

Mounting Dimensions (mm) :LFP1300W-B / LFP1400.2W-B / LFP1500W-B / LFP1600W-B

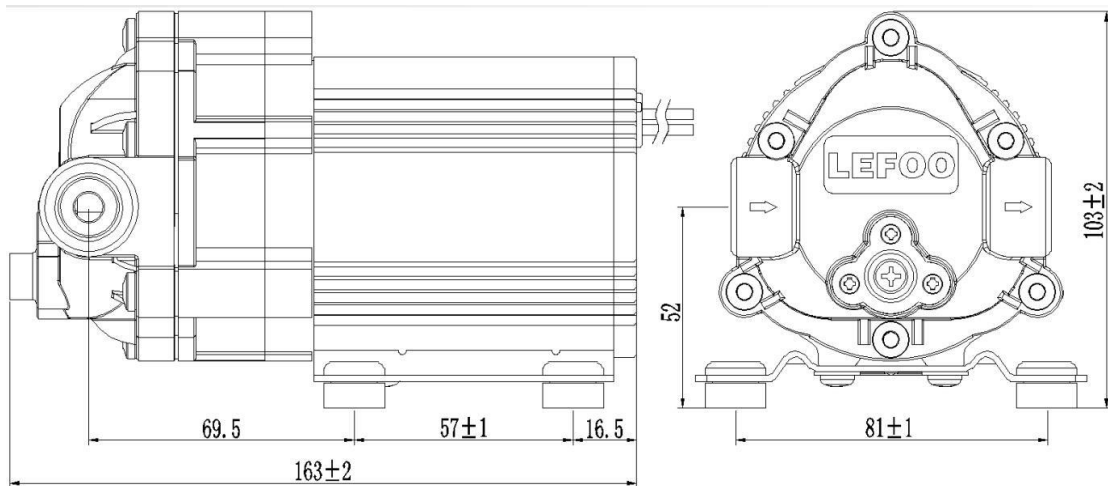

Mounting Dimensions (mm) :LFP2800W-B / LFP21000W-B

