

ABOUT LEFOO



LEFOO was founded in 2000, which is a National High-tech Enterprise of R&D, manufacturing, and sales.

LEFOO has been awarded "Little Giant" firms and "Specialized and Sophisticated Enterprises" by the Ministry of Industry and Information Technology of the People's Republic of China. LEFOO is a group company with 3 subsidiary corporations,

LEFOO Industrial Co., Ltd, LEFOO Controls Co., Ltd, and Zhejiang LEFOO Sensing Technology Co., Ltd. LEFOO is committed to become the leading and world-class enterprise in R&D and manufacturing to supply professional water pumps, mechanical structure controls, electronic digital sensing controls, which can be widely used in water purification, water treatment, home appliances, drink and beverage, environmental control, mechanical equipment, intelligent equipment, medical, power, Internet of things, and other industrial fields.

LEFOO already passed international management system certifications of ISO9001, ISO16949, ISO45001, ISO14001 and LEFOO has passed many product certifications of CE, RoHS, FDA, NSF, UL, CSA, 3C that authorized by TUV and SGS. LEFOO has more than 130 patents in total, includes 9 patents for invention. Over the past 20 years, LEFOO's market throughout more than 80 countries and regions in North America, South America, Europe, Asia, Africa, and Australia. As a professional and trustworthy supplier, LEFOO has cooperated and established strategic partnership with many great companies, Fortune Global 500, and world-famous brands.

"Quality & Service First, Focus on Technology & Innovation", adhering to this philosophy, LEFOO will continue to do best to meet the growing market requirements, provide advanced, reliable and exquisite products and service to all of customers.

DEMAND / DELIVERY PUMP

Product Overview //

Demand / delivery pump is a diaphragm positive displacement pump, the diaphragm plate plays a sealing and protective role in isolating the conveying medium and the power end (motor), and the regular movement of the diaphragm plate changes the volume of the studio, thereby inhaling and discharging the liquid to achieve liquid transportation and pressurization. The pump head is provided with a micro-switch through the valve plate, and the micro-switch forms a series effect with the motor end. When the pressure rises, the valve disc deforms under the pressure, triggering the micro-switch to power off; When the pressure is reduced, the valve disc recovers the deformation, and the micro-switch recovers the power, so as to realize the automatic start and stop. Multi-field application, can be used for RV water supply, Marine yacht water supply, solar water pump system, faucet end pressurization, automatic filling equipment, liquid vending machine, equipment water circulation cooling, water purification and drinking water, agricultural spray system, high pressure cleaning system and so on.



Application Area //



Rv, boat and yacht water supply



Solar water pump faucet end pressurization automatic filling equipment



Vending Machines



Water circulating and cooling. Water purification and drinking.



Agricultural spraying system. High pressure cleaning system.

Product Features //

- **Motor:** Fully enclosed permanent magnet motor
- **Base:** Metal base with cushioned Rubber pads
- **Inlet and outlet:** 3/8" Female quick connector. NPT3/8 thread
- **Type:** Three-chamber diaphragm pressurization
- **Materials for wading parts:** Pump head housing: Nylon
Valve plate: EPDM
Diaphragm: Santoprene
Fastener: Stainless steel
- **Temperature protection:** For user safety and maximum motor life, the motor is equipped with a thermal protector, and when the shell temperature reaches 73 °C, the operation is disconnected

Features and advantages

- **Automatic start-stop**
Can achieve high voltage power off, low voltage start
- **High performance motor**
All copper motor, strong power, low temperature rise, continuous work
- **Multiple pressure break points**
The pressure is adjustable from 30 to 100PSI
- **Integrated reflux relief device**
Bypass reflux reduces frequent start and stop of the pressure switch
- **High self priming capacity**
Self-priming height ≥2 meters, suction cavity and discharge cavity for three independent structure, high stability
- **Smooth flow**
The outlet end is designed with buffer structure, which has lower water pulse and vibration
- **High strength**
The bearing parts are reinforced nylon and aluminum alloy
- **Processize**
Electrical, sealing, pressurization and other performance production process full inspection control

Low electromagnetic noise and vibration ...
The motor adopts an integrated magnetization process, with lower electromagnetic noise and vibration

Good water resistance ...
Full range IPX5

Check function ...
Non-reverse structure design to prevent the backflow of the medium

Overheat protection ...
Equipped with a thermal protector, the pump shell temperature is higher than 73 °C, can realize automatic stop work

Authoritative certification ...
ROSH, CE, CQC, REACH Certification

High stability ...
Stable output and disconnect pressure, long life

LFP6060T

230VAC 0.6GPM Automatic Shut Off Demand/Delivery Diaphragm Pump



Flow Rate Curve

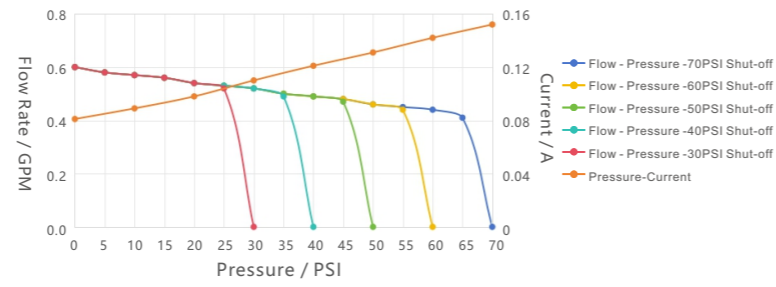

Temperature Rise Curve

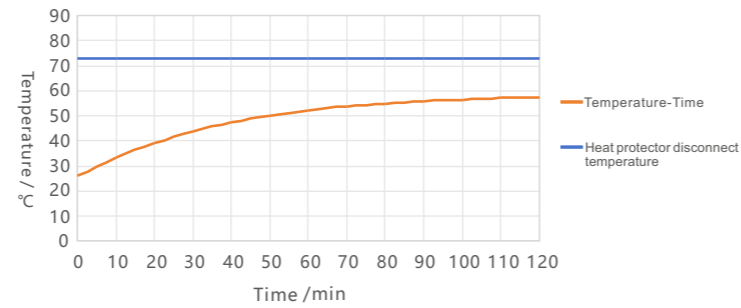

Performance data and curves

Data were tested at inlet pressure of 0PSI, ambient temperature and water temperature of 25°C. The above test data are based on a standard pipe of 3/8".

Temperature rise curve

The temperature rise curve is measured by the ambient temperature of 25°C, the inlet pressure of 0PSI, and the working pressure of 70PSI. In order to ensure the safety of the motor, the housing temperature exceeds approximately 73 °C, and the thermal protector is disconnected to cool the motor. The motor will be continuous working when the actual temperature rise of the motor is lower than the thermal protection disconnection temperature. All performance data and temperature curves are approximate, and actual conditions will vary with ambient conditions such as temperature.

Performance parameter

Discharge Pressure /PSI	Flow Rate /GPM	Flow Rate /LPM	Current /A
0	0.60	2.27	0.081
10	0.57	2.16	0.089
20	0.54	2.06	0.098
30	0.52	1.96	0.11
40	0.49	1.86	0.121
50	0.46	1.74	0.131
60	0.44	1.66	0.142
70	0.41	1.54	0.152

Shut-off pressure for selection

Selection	Rated voltage	Inlet Water Pressure	Working Flow Rate	Working Current	Suction	Shut-off Pressure	Maximum current	Connection
LFP6060T-30070	230V AC	0PSI	0.6GPM	≤0.14A	≥2M	70PSI	≤0.21A	3/8" side female quick connector NPT3/8 Screw thread
LFP6060T-30060						60PSI	≤0.20A	
LFP6060T-30050						50PSI	≤0.19A	
LFP6060T-30040						40PSI	≤0.18A	
LFP6060T-30030						30PSI	≤0.17A	

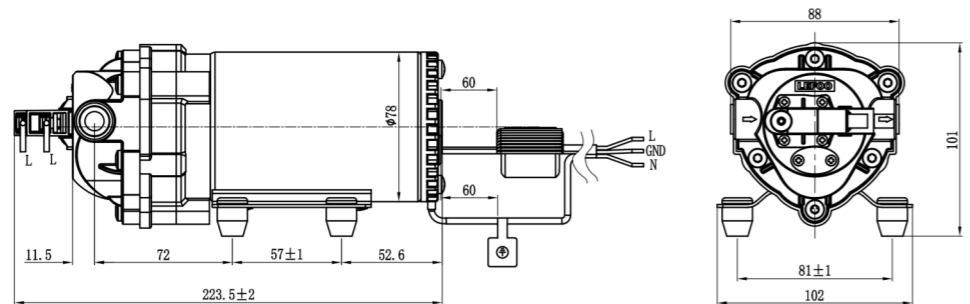

LFP6075T

230VAC 0.75GPM Automatic Shut-Off Demand/Delivery Diaphragm Pump



Flow Rate Curve

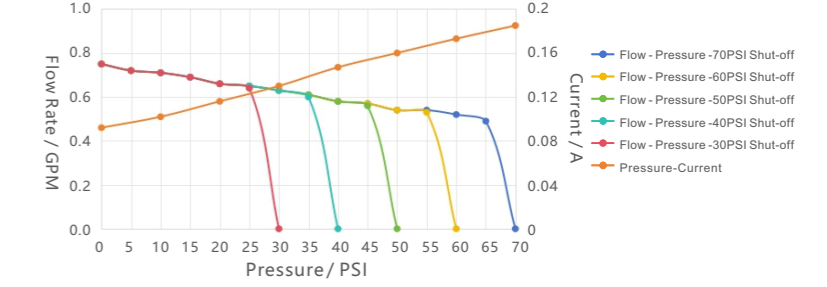

Temperature Rise Curve

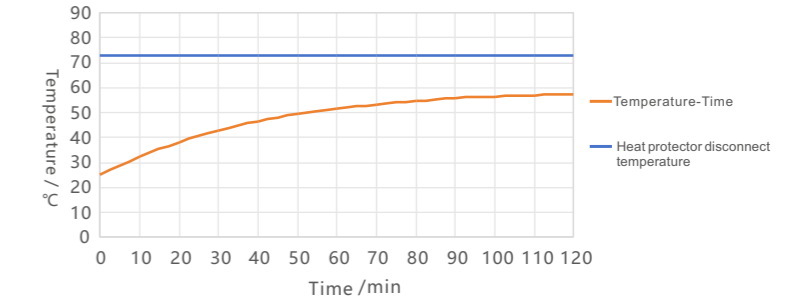

Performance data and curves

Data were tested at inlet pressure of 0PSI, ambient temperature and water temperature of 25°C. The above test data are based on a standard pipe of 3/8".

Temperature rise curve

The temperature rise curve is measured by the ambient temperature of 25°C, the inlet pressure of 0PSI, and the working pressure of 70PSI. In order to ensure the safety of the motor, the housing temperature exceeds approximately 73 °C, and the thermal protector is disconnected to cool the motor. The motor will be continuous working when the actual temperature rise of the motor is lower than the thermal protection disconnection temperature. All performance data and temperature curves are approximate, and actual conditions will vary with ambient conditions such as temperature.

Performance parameter

Discharge Pressure /PSI	Flow Rate /GPM	Flow Rate /LPM	Current /A
0	0.75	2.84	0.092
10	0.71	2.68	0.102
20	0.66	2.51	0.116
30	0.63	2.4	0.13
40	0.58	2.21	0.147
50	0.54	2.05	0.16
60	0.52	1.96	0.173
70	0.50	1.9	0.185

Shut-off pressure for selection

Selection	Rated voltage	Inlet Water Pressure	Working Flow Rate	Working Current	Suction	Shut-off Pressure	Maximum current	Connection
LFP6075T-30070	230V AC	0PSI	0.75GPM	≤0.15A	≥2M	70PSI	≤0.25A	3/8" side female quick connector NPT3/8 Screw thread
LFP6075T-30060						60PSI	≤0.23A	
LFP6075T-30050						50PSI	≤0.22A	
LFP6075T-30040						40PSI	≤0.20A	
LFP6075T-30030						30PSI	≤0.19A	

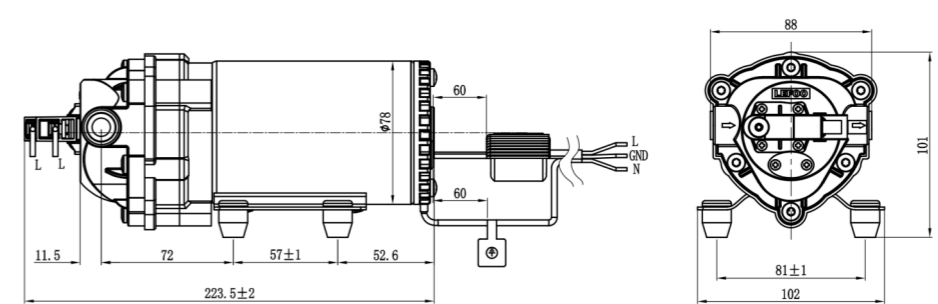

LFP6085T

230VAC 0.85GPM Automatic Shut Off Demand/Delivery Diaphragm Pump



○ Flow Rate Curve

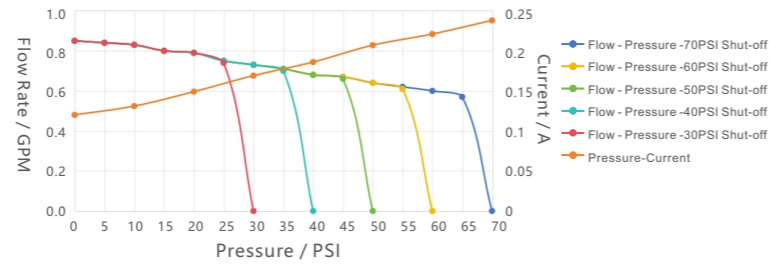

○ Temperature Rise Curve

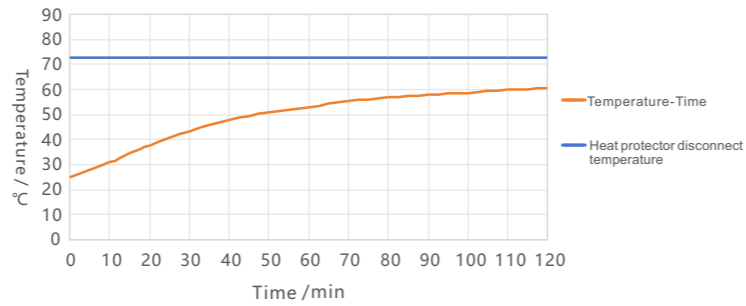

○ Performance data and curves

Data were tested at inlet pressure of 0PSI, ambient temperature and water temperature of 25°C. The above test data are based on a standard pipe of 3/8".

○ Temperature rise curve

The temperature rise curve is measured by the ambient temperature of 25°C, the inlet pressure of 0PSI, and the working pressure of 70PSI. In order to ensure the safety of the motor, the housing temperature exceeds approximately 73 °C, and the thermal protector is disconnected to cool the motor. The motor will be continuous working when the actual temperature rise of the motor is lower than the thermal protection disconnection temperature. All performance data and temperature curves are approximate, and actual conditions will vary with ambient conditions such as temperature.

○ Performance parameter

Discharge Pressure /PSI	Flow Rate /GPM	Flow Rate /LPM	Current /A
0	0.85	3.22	0.12
10	0.83	3.14	0.131
20	0.79	2.99	0.149
30	0.73	2.76	0.169
40	0.68	2.59	0.186
50	0.64	2.41	0.207
60	0.60	2.26	0.221
70	0.56	2.12	0.238

○ Shut-off pressure for selection

Selection	Rated voltage	Inlet Water Pressure	Working Flow Rate	Working Current	Suction	Shut-off Pressure	Maximum current	Connection
LFP6085T-30070	230V AC	0PSI	0.85GPM	≤0.18A	≥2M	70PSI	≤0.3A	3/8" side female quick connector NPT3/8 Screw thread
LFP6085T-30060						60PSI	≤0.28A	
LFP6085T-30050						50PSI	≤0.27A	
LFP6085T-30040						40PSI	≤0.25A	
LFP6085T-30030						30PSI	≤0.23A	

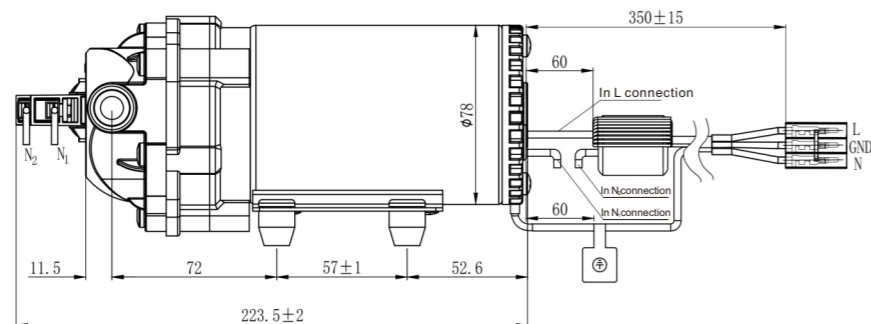

LFP6100T

230VAC 1.0GPM Automatic Shut-Off Demand/Delivery Diaphragm Pump



○ Flow Rate Curve

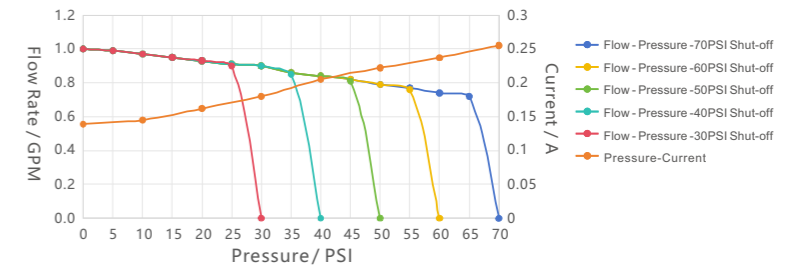

○ Temperature Rise Curve

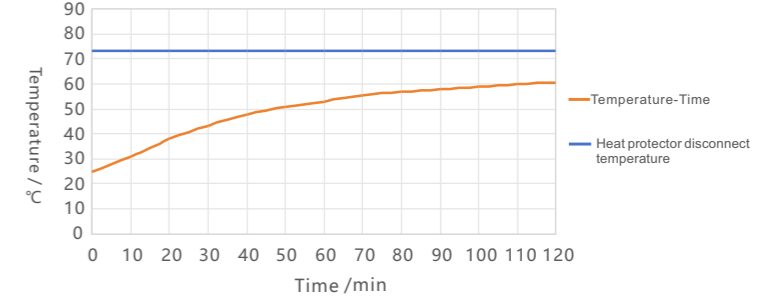

○ Performance data and curves

Data were tested at inlet pressure of 0PSI, ambient temperature and water temperature of 25°C. The above test data are based on a standard pipe of 3/8".

○ Temperature rise curve

The temperature rise curve is measured by the ambient temperature of 25°C, the inlet pressure of 0PSI, and the working pressure of 70PSI. In order to ensure the safety of the motor, the housing temperature exceeds approximately 73 °C, and the thermal protector is disconnected to cool the motor. The motor will be continuous working when the actual temperature rise of the motor is lower than the thermal protection disconnection temperature. All performance data and temperature curves are approximate, and actual conditions will vary with ambient conditions such as temperature.

○ Performance parameter

Discharge Pressure /PSI	Flow Rate /GPM	Flow Rate /LPM	Current /A
0	1.0	3.79	0.139
10	0.97	3.69	0.145
20	0.93	3.53	0.162
30	0.90	3.41	0.180
40	0.84	3.18	0.205
50	0.79	2.99	0.222
60	0.74	2.8	0.237
70	0.70	2.64	0.255

○ Shut-off pressure for selection

Selection	Rated voltage	Inlet Water Pressure	Working Flow Rate	Working Current	Suction	Shut-off Pressure	Maximum current	Connection
LFP6100T-30070	230V AC	0PSI	1.0GPM	≤0.2A	≥2M	70PSI	≤0.31A	3/8" side female quick connector NPT3/8 Screw thread
LFP6100T-30060						60PSI	≤0.3A	
LFP6100T-30050						50PSI	≤0.28A	
LFP6100T-30040						40PSI	≤0.26A	
LFP6100T-30030						30PSI	≤0.24A	

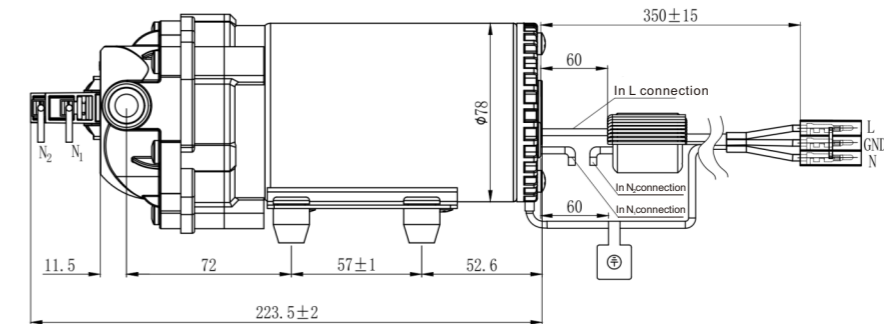

LFP6115T

230VAC 1.15GPM Automatic Shut Off Demand/Delivery Diaphragm Pump



○ Flow Rate Curve

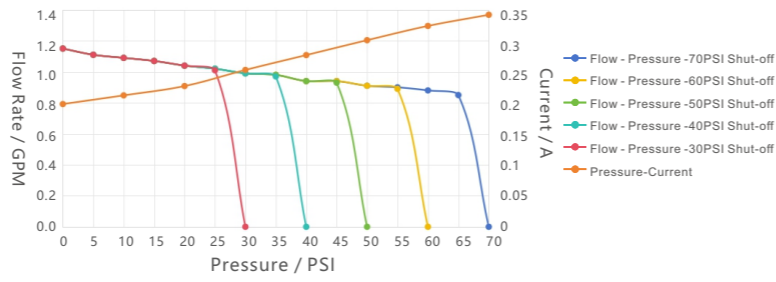

○ Temperature Rise Curve

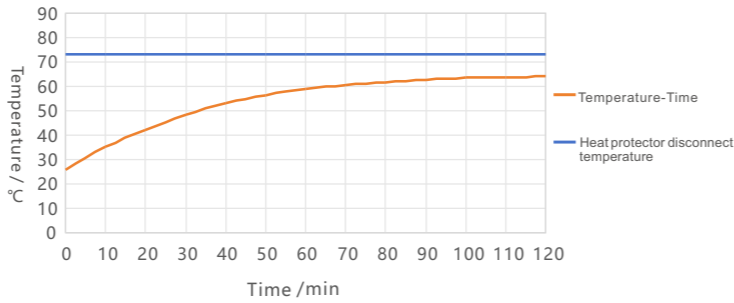

○ Performance data and curves

Data were tested at inlet pressure of 0PSI, ambient temperature and water temperature of 25°C. The above test data are based on a standard pipe of 3/8".

○ Temperature rise curve

The temperature rise curve is measured by the ambient temperature of 25°C, the inlet pressure of 0PSI, and the working pressure of 70PSI. In order to ensure the safety of the motor, the housing temperature exceeds approximately 73 °C, and the thermal protector is disconnected to cool the motor. The motor will be continuous working when the actual temperature rise of the motor is lower than the thermal protection disconnection temperature. All performance data and temperature curves are approximate, and actual conditions will vary with ambient conditions such as temperature.

○ Performance parameter

Discharge Pressure /PSI	Flow Rate /GPM	Flow Rate /LPM	Current /A
0	1.15	4.35	0.198
10	1.09	4.11	0.212
20	1.04	3.93	0.227
30	0.99	3.73	0.253
40	0.94	3.57	0.277
50	0.91	3.43	0.301
60	0.88	3.33	0.324
70	0.86	3.25	0.342

○ Shut-off pressure for selection

Selection	Rated voltage	Inlet Water Pressure	Working Flow Rate	Working Current	Suction	Shut-off Pressure	Maximum current	Connection
LFP6115T-30070	230V AC	0PSI	1.15GPM	≤0.25A	≥2M	70PSI	≤0.39A	3/8" side female quick connector NPT3/8 Screw thread
LFP6115T-30060						60PSI	≤0.37A	
LFP6115T-30050						50PSI	≤0.35A	
LFP6115T-30040						40PSI	≤0.33A	
LFP6115T-30030						30PSI	≤0.30A	

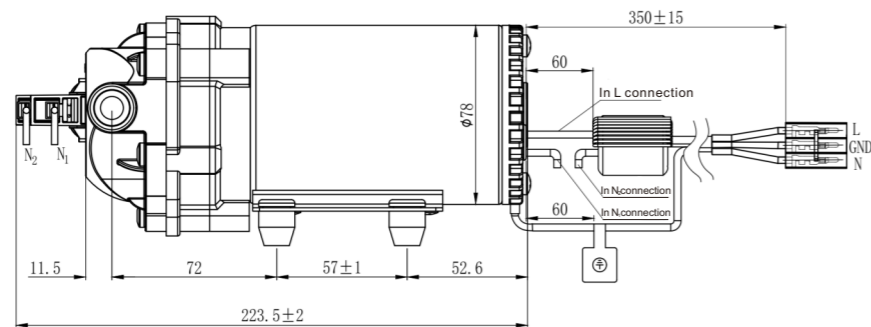

LFP6125T

230VAC 1.25GPM Automatic Shut-Off Demand/Delivery Diaphragm Pump



○ Flow Rate Curve

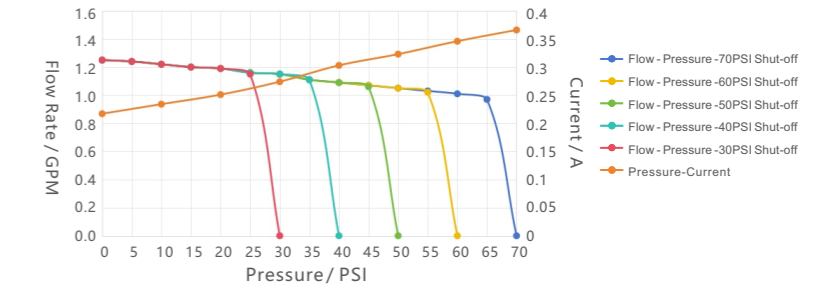

○ Temperature Rise Curve

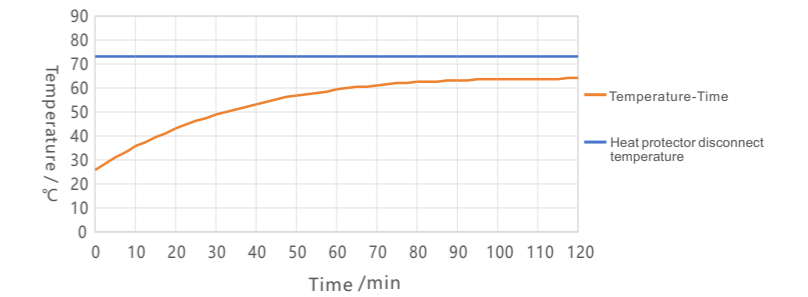

○ Performance data and curves

Data were tested at inlet pressure of 0PSI, ambient temperature and water temperature of 25°C. The above test data are based on a standard pipe of 3/8".

○ Temperature rise curve

The temperature rise curve is measured by the ambient temperature of 25°C, the inlet pressure of 0PSI, and the working pressure of 70PSI. In order to ensure the safety of the motor, the housing temperature exceeds approximately 73 °C, and the thermal protector is disconnected to cool the motor. The motor will be continuous working when the actual temperature rise of the motor is lower than the thermal protection disconnection temperature. All performance data and temperature curves are approximate, and actual conditions will vary with ambient conditions such as temperature.

○ Performance parameter

Discharge Pressure /PSI	Flow Rate /GPM	Flow Rate /LPM	Current /A
0	1.25	4.73	0.217
10	1.22	4.62	0.234
20	1.19	4.51	0.251
30	1.15	4.34	0.274
40	1.09	4.12	0.303
50	1.05	3.97	0.323
60	1	3.8	0.346
70	0.96	3.62	0.366

○ Shut-off pressure for selection

Selection	Rated voltage	Inlet Water Pressure	Working Flow Rate	Working Current	Suction	Shut-off Pressure	Maximum current	Connection
LFP6125T-30070	230V AC	0PSI	1.25GPM	≤0.28A	≥2M	70PSI	≤0.43A	3/8" side female quick connector NPT3/8 Screw thread
LFP6125T-30060						60PSI	≤0.41A	
LFP6125T-30050						50PSI	≤0.38A	
LFP6125T-30040						40PSI	≤0.36A	
LFP6125T-30030						30PSI	≤0.33A	

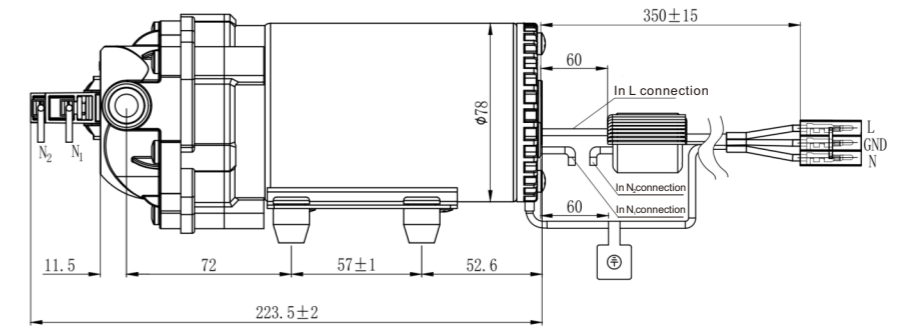

LFP6140T

230VAC 1.4GPM Automatic Shut Off Demand/Delivery Diaphragm Pump



○ Flow Rate Curve

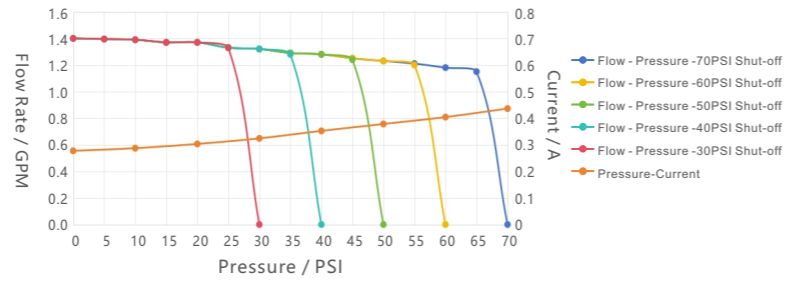

○ Temperature Rise Curve

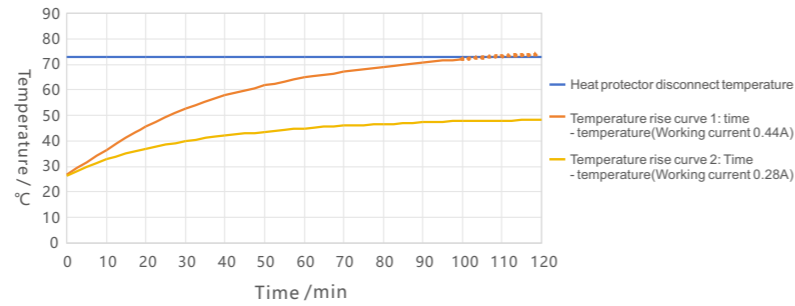

○ Performance data and curves

Data were tested at inlet pressure of 0PSI, ambient temperature and water temperature of 25°C. The above test data are based on a standard pipe of 3/8".

○ Temperature rise curve

In order to ensure the safety of the motor, the housing temperature exceeds approximately 73°C, and the thermal protector is disconnected to cool the motor. Temperature rise curve 1 is measured by ambient temperature 25°C, inlet pressure 0PSI, and working pressure 70PSI. The actual operation of the motor under this condition is 100min. Left and right will be higher than the heat protector disconnect temperature, can not be continuous work. Temperature rise curve 2 is measured by ambient temperature 25°C, inlet pressure 0PSI, and working pressure 0PSI. The actual temperature of the motor under this condition is lower than the disconnecting temperature of the thermal protector, and can be entered line continuity work. All performance data and temperature curves are approximate, and actual conditions will vary with ambient conditions such as temperature.

○ Performance parameter

Discharge Pressure /PSI	Flow Rate /GPM	Flow Rate /LPM	Current /A
0	1.40	5.3	0.277
10	1.39	5.27	0.287
20	1.37	5.2	0.303
30	1.32	5.01	0.324
40	1.28	4.84	0.352
50	1.23	4.64	0.400
60	1.18	4.47	0.440
70	1.12	4.24	0.440

○ Shut-off pressure for selection

Selection	Rated voltage	Inlet Water Pressure	Working Flow Rate	Working Current	Suction	Shut-off Pressure	Maximum current	Connection
LFP6140T-30070	230V AC	0PSI	1.40GPM	≤0.33A	≥2M	70PSI	≤0.49A	3/8"side female quick connector NPT3/8 Screw thread
LFP6140T-30060						60PSI	≤0.45A	
LFP6140T-30050						50PSI	≤0.43A	
LFP6140T-30040						40PSI	≤0.40A	
LFP6140T-30030						30PSI	≤0.37A	

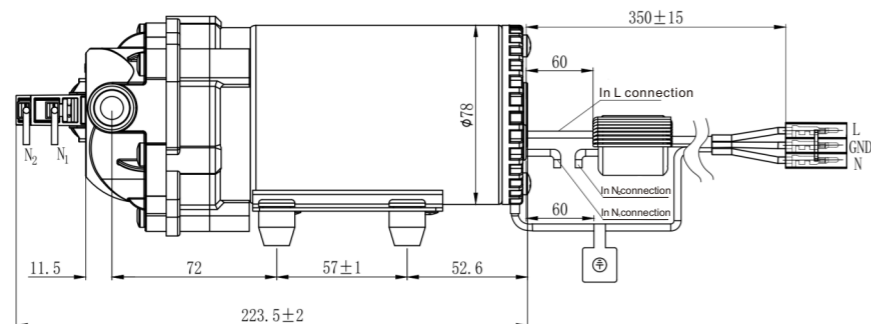

LFP6150T

230VAC 1.5GPM Automatic Shut-Off Demand/Delivery Diaphragm Pump



○ Flow Rate Curve

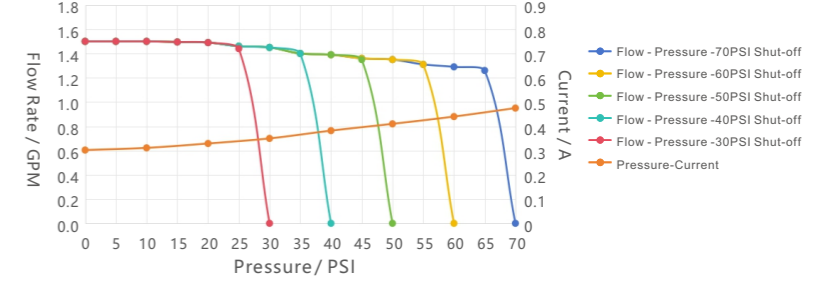

○ Temperature Rise Curve

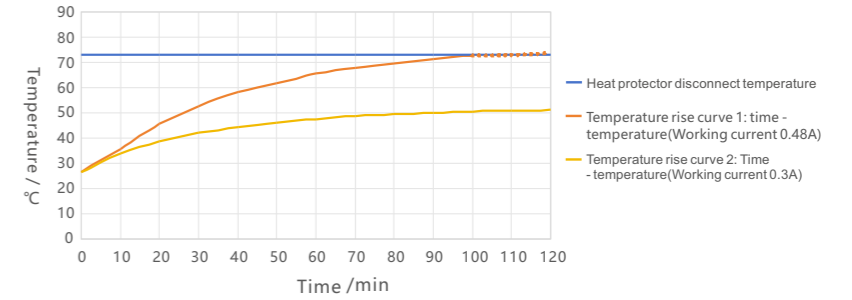

○ Performance data and curves

Data were tested at inlet pressure of 0PSI, ambient temperature and water temperature of 25°C. The above test data are based on a standard pipe of 3/8".

○ Temperature rise curve

In order to ensure the safety of the motor, the housing temperature exceeds approximately 73°C, and the thermal protector is disconnected to cool the motor. Temperature rise curve 1 is measured by ambient temperature 25°C, inlet pressure 0PSI, and working pressure 70PSI. The actual operation of the motor under this condition is 100min. Left and right will be higher than the heat protector disconnect temperature, can not be continuous work. Temperature rise curve 2 is measured by ambient temperature 25°C, inlet pressure 0PSI, and working pressure 0PSI. The actual temperature of the motor under this condition is lower than the disconnecting temperature of the thermal protector, and can be entered line continuity work. All performance data and temperature curves are approximate, and actual conditions will vary with ambient conditions such as temperature.

○ Performance parameter

Discharge Pressure /PSI	Flow Rate /GPM	Flow Rate /LPM	Current /A
0	1.50	5.68	0.302
10	1.50	5.69	0.311
20	1.49	5.63	0.329
30	1.45	5.47	0.350
40	1.39	5.28	0.382
50	1.35	5.11	0.400
60	1.29	4.89	0.440
70	1.22	4.6	0.480

○ Shut-off pressure for selection

Selection	Rated voltage	Inlet Water Pressure	Working Flow Rate	Working Current	Suction	Shut-off Pressure	Maximum current	Connection
LFP6150T-30070	230V AC	0PSI	1.50GPM	≤0.36A	≥2M	70PSI	≤0.54A	3/8"side female quick connector NPT3/8 Screw thread
LFP6150T-30060						60PSI	≤0.5A	
LFP6150T-30050						50PSI	≤0.47A	
LFP6150T-30040						40PSI	≤0.44A	
LFP6150T-30030						30PSI	≤0.41A	

